

**To the Body of European Regulators  
for Electronic Communications**

[NTP\\_Guidelines@berec.europa.eu](mailto:NTP_Guidelines@berec.europa.eu)

ALLNET.ITALIA S.p.A. is a high value-added distributor in Italy and Spain, specializing in innovative solutions, information technology and telecommunications. Through a constant search for innovative technologies and a highly specialized team, it provides complete ICT solutions for small and medium-sized enterprises, public administration, banking sector and industrial sector. ALLNET.ITALIA operates exclusively through system integrators, ISPs, installers and certified resellers throughout the Italian territory, as well as in neighboring countries.

Our interest is determined by the obvious fact that we sell these products to our customers, who install them for other companies or end users. But furthermore we want to represent the interests of both System Integrators and end users; for the former it's important to guarantee the *freedom of choice and configuration of the product that best suits the needs of the end user*; for the latter, the prospect of adopting new technologies must not be limited in any way by the NTP.

**Allnet.Italia. S.p.A., in the context of the ongoing consultation BoR (19) 181, has formally adopted the following common Statement, in the hope that it could positively contribute to BEREC's activities on the matter.**

\*\*\*\*\*

**Statement on the draft “BEREC Guidelines on Common Approaches to the Identification of the  
Network Termination Point in different Network Topologies”  
BoR (19) 181**

We expressly welcome the fact that BEREC is concerned with determining the network termination point (NTP), the physical point at which an end-user is provided with access to a public communications network. The location of the NTP is decisive when it comes to whether end-users have a free choice of their terminal device or not, as well as for the competition in the TTE market.

A clear definition of the NTP at point A ensures the end-users' free choice of terminal equipment by preventing the network operators from arbitrarily determining the location of the NTP and thus extending their market power into the area of telecommunications terminal equipment. It furthermore fosters innovation and competition among the TTE manufacturers with regard to all categories of devices – from a single modem to a highly integrated terminal device with a modem, router, WiFi, VoIP etc. (IAD<sup>1</sup>)

---

<sup>1</sup> An Integrated Access Device (IAD) simultaneously supports multiple communications services such as telephony, Voice over IP (VoIP) and data services. For example, an IAD integrates a modem and a router; a modem, a router and VoIP; a modem, a router and WiFi; a modem and VoIP, and so on).

With regard to the draft of the BEREC Guidelines on Common Approaches to the Identification of the Network Termination Point in different Network Topologies, we have the following comments and/or suggestions:

- BEREC should clearly state in the guidelines that it is in favour of point A as the NTP or make it even clearer that point A should be the rule when determining the NTP.**

Various statements in the draft Guidelines indicate that, from BEREC's point of view, the NTP should normally be at point

A. In this respect, we are in favour of BEREC expressly stating once again in the draft guidelines that the NTP at point A is the rule. This would counteract a potentially inconsistent interpretation of the guidelines and clearly contribute to their consistent application by the national regulatory authorities.

We would like to explain this requirement by briefly outlining the advantages of a NTP at point A and the disadvantages of a NTP at point B or C.

An NTP located at point A would have the following advantages:

**Fig. 1: Model A**

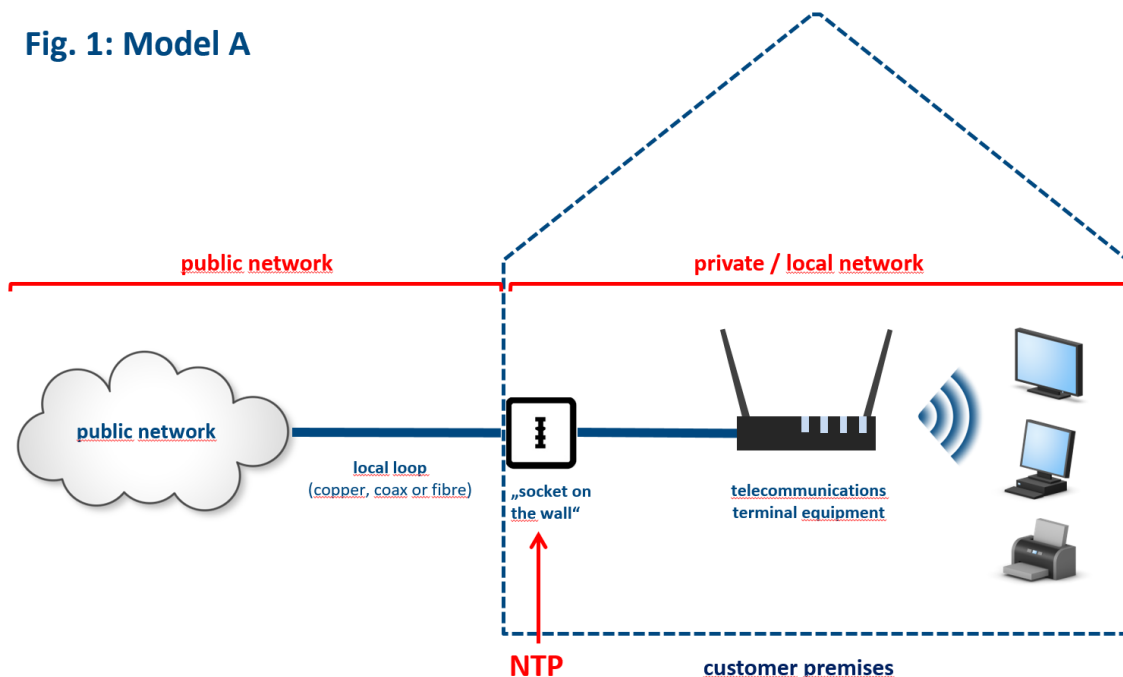

- It gives the end-user complete freedom to choose and connect the terminal equipment in their home that best meets their needs and desires.
- It clearly separates the public telecommunications network from the end-user's private network.
- It allows the end-user to use an IAD as an all-in-one solution with low costs or separate terminal devices for separate services.
- It ensures the lowest possible power consumption for the end-user.
- It reduces the total cost of ownership as far as possible as there is no rent for an obligatory terminal device.
- End-users can keep their terminal devices even when they switch providers; this bypasses the potentially extensive setup effort for new devices (also in the local network).

- It creates a level playing field for European TTE vendors and promotes competition in the TTE market.
- Competition for the best terminal device encourages innovation at all technical levels. This in turn also has a positive impact on prices from which the end-user ultimately benefits.
- It makes possible the comprehensive participation of retailers in the value chain and adds value for system houses and consulting trade. This leads to more know how and support on all levels of the value-added chain.
- It allows unrestricted access to all services (e.g. VoIP) at the connection.
- Direct access to the physical layer is the only way to facilitate competition in wholesale scenarios.
- With a view to digital sovereignty, it safeguards the expertise and know-how of European terminal equipment manufacturers and vendors in Europe.

**1. The draft Guidelines should clarify the impact of the definition of the NTP at point B (a.o. paragraph 3.3.1.2 and 3.3.2.2).**

From the draft BEREC guidelines there is no doubt that the modem must be a so-called "standalone modem": Point 53. b. states that in model B, "[t]he NTP is the interface at the end-users' side of the modem". According to BEREC, the modem's properties represent the network termination, but it must not have any other functionalities such as switching, routing or WiFi. BEREC even gives examples of such a modem: a traditional DSL modem, fiber optic modem or cable modem. It follows from this that the modem in model B is necessarily a so-called "standalone modem" - i.e. explicitly no integrated device with the component "modem".

In the event that the NTP was defined at point B, this meant that the modem and router could not be integrated in one device (IAD). It is also not intended to "lead out" point B from an integrated device. This means that the "standalone modem" must NOT be replaced by an integrated device that is only switched to bridge mode.

This would then mean that in Model B the network operator would have to provide each of its customers with a "standalone modem" without further functionalities as the network termination, since the device would be part of its telecommunications network.

In our view, BEREC's comments so far do not make this sufficiently clear, especially as it would have devastating consequences for competition in the terminal equipment market; IADs could no longer be used and terminal equipment manufacturers would be deprived of their commercial basis.

An NTP located at point B would have the following disadvantages:

**Fig. 2: Model B**

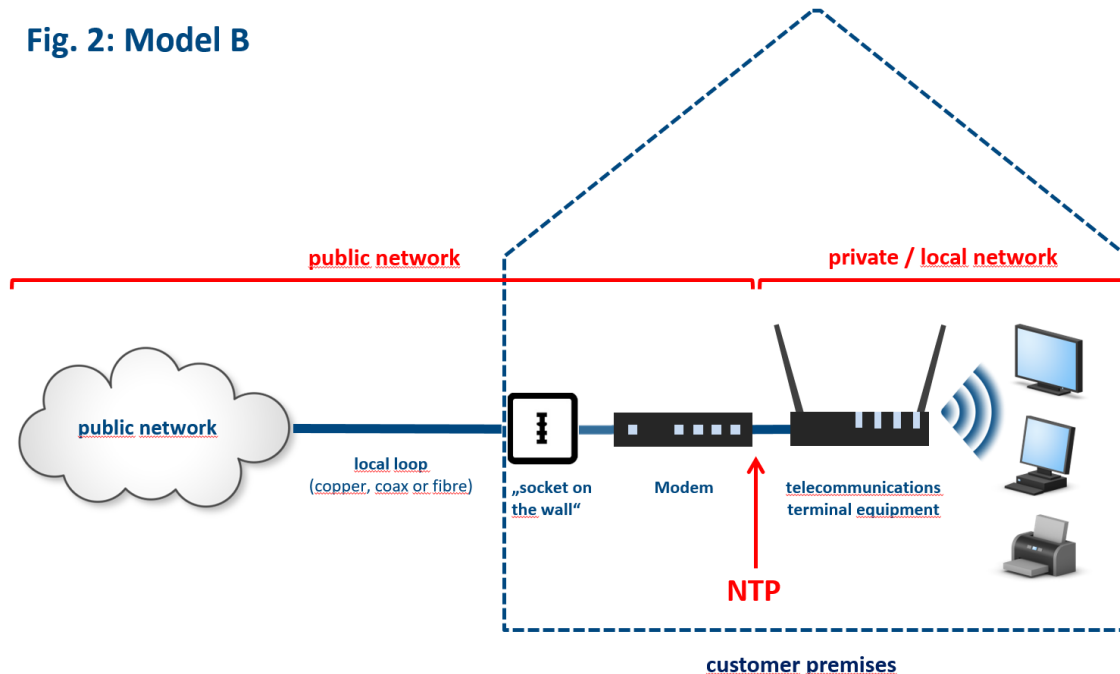

- The end-user's free choice of terminal equipment is massively restricted.
- The public telecommunications network under the sovereignty of the provider no longer ends at the "socket on the wall", but expands into the premises of the end-user.
- An IAD can no longer be used. Instead, the end-user now has to use two separate devices – the standalone modem and another device for internet access, Firewall, WiFi, Smart Home or telephony; but:
  - Two devices might be unsatisfactory for the end-user as there are numerous cables, two power supply units, a more complex installation process, the fault finding are considered unsatisfactory from the customer's point of view as there are too many cables, two power supply units, a more complex installation, the fault finding is more complex etc.
  - Two devices increase the risk of things going wrong.
  - And from the point of view of network management, two devices have to be supported, which leads to increased expenditure in the event of a fault, leading to greater customer dissatisfaction.

However, from a technical perspective, the standalone modem is in full retreat in practice. The chip maps of all leading semiconductor manufacturers show an integration of the modem function with the voice function, the router function, a powerful processor and partly WiFi, security and other functions for a gateway.

- Having to connect terminal device behind a standalone modem would result in an increase in power demand. The end-user would have to pay double for the electricity which in turn would also have an environmental impact. Moreover, problems can also arise from the fact that the end-user pays electricity for a device that is part of the public telecommunications network under the sovereignty of the provider and that they do not control.
- Terminal monocultures (here with regard to standalone modems) are attractive targets for hackers who want to exploit security gaps that may arise. In the event of a security incident, a large number of terminal devices are immediately affected.

- If the NTP is located at point B the market for TTE with an integrated modem (such as IADs) would de facto cease to exist because an integration of modem and other functionalities would be not allowed according to the draft BEREC Guidelines. The market for IAD is the most popular and most important part of the TTE market. Therefore for the terminal equipment market, this would mean a massive restriction of competition. IADs could neither be offered to end-users by the network operator nor by the manufacturers in the market. The clear trend towards integrated devices would be abruptly halted and innovation in this area brought to a standstill. This would also mean that the advantages of device integration ("everything in one device") - especially for the end-user - would be lost. In addition, the wholesale level, such as chip and component manufacturers as well as retailers and system houses would have significantly restricted markets.
- Increased investment costs for providers, as they would have to provide each of their customers with an obligatory modem and at the same time also offer a second, higher-quality integrated device (e.g. with firewall, WLAN or DECT) that meets customer needs.

Not only an NTP located at point B, but **also an NTP located at point C would have disadvantages for end-users, competition in the TTE market, security etc.:**

**Fig. 3: Model C**

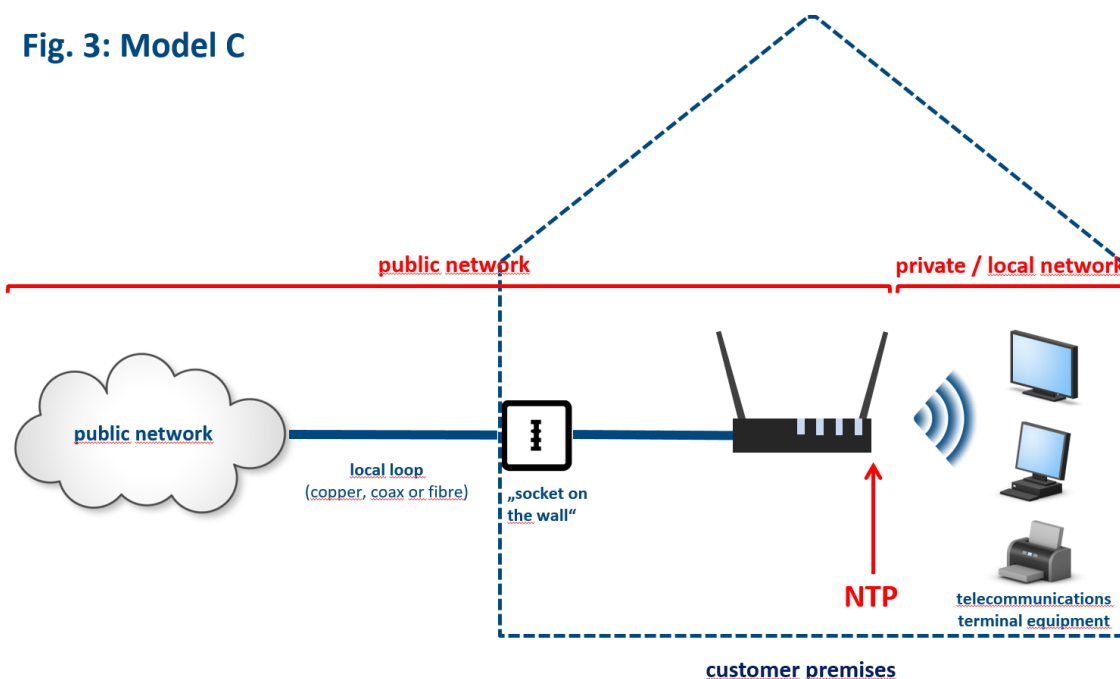

- The end-user no longer has a choice about the terminal device on their connection.
- The terminal equipment in the end-user's premise is part of the public telecommunications network under the sovereignty of the provider.
- The end-user must supply the terminal equipment in their home with electricity even though they have no sovereignty over it and it is part of the public telecommunications network (and not their private network).
- In many cases, the end-user has to pay the purchase or rental costs for the compulsory terminal, but ultimately has no sovereignty over it as it is part of the provider's public network.

- Additional costs may also be incurred if the end-user has to pay an extra activation fee for WiFi or Smart Home functions.

- Switching from one provider to another is made significantly more difficult because it inevitably entails a change of the terminal equipment. As a result, both the new terminal device and all devices connected to it in the local network have to be reconfigured (e.g. WiFi, telephony, firewall settings, etc.).

- If the NTP is located at point C, the network operators unilaterally transfer the market power, volume and also revenue from the market for telecommunications terminal equipment to themselves, thus depriving the many terminal equipment manufacturers of their business basis.

- A very large number of merchants, system houses or electronics markets lose their market due to the terminal equipment forcibly marketed by the provider. The free terminal equipment market is thus ultimately wiped out, which has significant negative economic consequences. Providers would be able to control all functionalities of the device remotely. Business models in which individual functions would be offered for a monthly fee (e.g. WiFi on/off, WiFi at a low or higher speed, simple or high voice quality, limitation of the number of the connected devices etc.) could see a significant increase, since the only alternative for the end-user would be to switch provider, which is already considerably more difficult with an NTP at Point C anyway.

- If the subscriber-side interfaces (LAN interfaces) of the terminal device represented the NTPs, then private communication between two LAN interfaces would be routed over a public network. This raises considerable data

protection issues. If the terminal device is under the network operator's control, the latter can theoretically access the end-user's private network (home network, company network). This means confidential information from the private network is no longer protected. Even if it can be assumed that network operators comply with all data protection regulations, there are still concerns, especially among end-users, against the background of past incidents (NSA, PRISM).

- The interfaces on the subscriber side of the terminal do not meet the regulatory requirements for the NTP (cf. EEECC). For example, the LAN interface does not provide access to a telecommunications network, but to the private network of the end-user's own devices at home (LAN). There would also be hardly any device that could be connected with this LAN interface, because the network devices connected to the LAN, e.g. PC, printer or smart TV, are not telecommunications terminals.

## 2. BEREC should further highlight the consequences of the different locations of the NTP on the TTE market (a.o. paragraph 3.2, "Impact on the TTE Market")

The market for TTE with an integrated modem (such as IADs) is the most popular and most important part of the TTE market in terms of customers, market volume and revenue and is therefore very important for many telecommunications terminal equipment manufacturers.

In the case of **model B**, the market for TTE with an integrated modem (such as IADs) could de facto cease to exist because the draft guidelines do not allow the integration of modems and other functionalities in this scenario.

For the terminal equipment market, this would mean a massive restriction of competition. TTE with an integrated modem (such as IADs) could neither be offered to end-users by the network operator nor by the manufacturers in the market. The clear trend towards integrated devices would be abruptly halted and innovation brought to a standstill. This would also mean that the advantages of device integration ("everything in one device") - especially for the end-user - would be lost.

In addition, the upstream suppliers of telecommunications terminal equipment, such as chip and other component manufacturers as well as retailers and system houses, would have significantly more restricted markets.

For network operators, Model B would also entail a considerably higher economic cost: they would have to provide all their customers with a "standalone modem" as a network component and, in line with customer expectations, market a second, higher-quality integrated device (e.g. with WLAN or DECT) for connection to the forced modem.

If the NTP is set at **point C**, the public telecommunications network ends behind the router. This means that all devices connected to the router (such as printers, smart televisions or refrigerators, etc.) are terminal devices.

With regard to competition in the terminal equipment market, this would mean that only providers would be able to market integrated equipment to their customers. This would de facto put an end to competition in the terminal equipment market, with disastrous consequences for terminal equipment manufacturers.

Only in **model A** is a free, competitive market for IAD possible, in which the NTP is defined at point A, the public telecommunications network ends at the end of the "local loop", i.e. at the "socket on the wall". In this case, both routers and modems, which in the vast majority of cases are integrated into one device (IADs), are terminal devices.

For the terminal equipment market this meant, as BEREC rightly points out, a high degree of competition. Both the terminal equipment manufacturers could market IADs in the retail market and the network operators could market IADs

to the end-user. End-users would then ultimately be able to choose the product that best meets their needs and desires.

Point A also has the following advantages with regard to the economic advantages, also in terms of the free internal market of the European Union: These include the comprehensive participation of trade in the value chain, innovative competition for the best terminal equipment. For example, the lively competition created by liberalisation in the telecommunications terminal equipment market has led to a wide range of innovative and high-performance products for connection to telecommunications networks. Only with the clear demarcation of telecommunications networks and terminal equipment a point A lively competition could develop in the market for telecommunications terminal equipment. This market is characterised by short innovation cycles, a pronounced product diversity and - based on this - unrestricted freedom of choice for users. Free and open competition for the best terminal device secures jobs, creates innovative strength and secures Europe as a tech location, especially in the medium-sized sector of terminal device manufacturers.

### **3. In assessing the "network security" criterion, Berec and NRAs should consider the existing evidence about the risks of terminal equipments' monocultures (par. 3.3.3)**

In particular, we want to highlight to BEREC the case that happened in Italy during October 2017, which affected many end-users. From the 29th of september 2017, with the problem growing in the following days, many clients of WIND-INFOSTRADA with fiber optic connections experienced serious malfunctioning, up to the total down of their internet connection. The failures quickly extended, involving practically all of the terminal equipments for fiber supplied by the operator in some geographical areas.

The source of the failures was probably a cyber attack, which clearly demonstrated that the claim of a greater security and resilience of the terminals supplied by an operator, rather than those freely purchasable on the market, is unfounded. It took weeks to restore the internet access of all the affected end-users and it became necessary for the operator to physically replace the modem-router at the user's premise. In the meantime, the end-users, being technically and contractually

---

prevented from using an own terminal equipment, were effectively denied internet access.

Had the users been allowed to use a different device, acquired on the retail market, they would have been able to access the internet without waiting a customer support which, in this case and as a consequence of the extreme extension of the failures, demonstrated its untimeliness and ineffectiveness.

We hereby provide some online sources about the case: [\(1\)](#), [\(2\)](#), [\(3\)](#), [\(4\)](#), [\(5\)](#), [\(6\)](#).

- 4. BEREC should consider the models A, B and C not only with regard to "conformity of the definition of the fixed NTP location with the legal provisions" "impact on the TTE market" and "objective technological necessities" of the network operators, but should also consider the "necessities of the consumers" who are in the focus of the freedom of terminal equipment or whose main addressees are.**

In the present draft, BEREC refers mostly to "objective technological necessities", which refer to the "public network". Ultimately, only the technological necessities of the public network, i.e. the network operators, are taken into account, the view or the necessities of the end-users are completely lacking.

We therefore argue that BEREC should also include "end-user necessities" as further evaluation criteria with regard to the models A, B and C.

In the objective technological necessities, BEREC fortunately already addresses end-user necessities such as security or data protection in individual areas.

However, we advocate that these existing criteria should be evaluated even more with regard to the end-user. In addition, we propose further evaluation criteria that are important for the end-user:

- **Digital sovereignty of the end-user (freedom of action and choice)**

The end-user's digital self-determination includes the possibility of action and choice. End-users throughout Europe already have the right to "use the devices of their choice".

In Model A, end-users have by far the greatest digital sovereignty. They can act independently and select and connect without restriction from a large number of innovative products on the market the terminal that best meets their wishes and needs.

The end-user has a clearly limited digital sovereignty with Model B. A modem is imposed on them over which they have no sovereignty. They only have the choice of a terminal connected to the modem, which, however, causes them additional electricity costs.

In model C, the digital sovereignty of the end-user is completely restricted. They cannot freely choose their terminal devices and no longer have sovereignty over them.

- **Change of network operator (switching)**

If the interfaces of a modem or router are the NTP(s) (model B or C), switching provider would force the end-user to also



---

switch the obligatory modem or IAD.

This turns out to be a significant barrier to switching providers as today's (WiFi) routers function as the central base station for home networks; they connect a range of WiFi devices (smartphones, computers, printers, speakers, TV sets, ...),

telephones and a range of smart home devices.

The requirement to replace the router when switching provider forces the end-user to reconfigure not only the router but, more importantly, all devices in the home network connected to it. This can be extremely complex, even for technically experienced end-users. End-users with less experience may be daunted by the technical effort and therefore avoid switching provider in the first place.

With model A, the end-user could continue to use his terminal device even if he changes providers.

- **Eco aspects / costs for the end-user**

connecting two devices in series (e.g. routers behind modems) would mean a significant increase in power requirements. With electricity prices also rising, this would have both environmental and economic disadvantages for the end-user due to the significantly higher costs involved.

With model A, using a highly efficient integrated device would be possible without any problems, considerably reducing power requirements. In addition, one of the selection criteria for the end-user could also be electricity consumption, which could also lead to more energy-efficient terminal equipment in the competition for the favor of the end-user.

For models B and C, the end-user has to pay the electricity cost of an additional device that they have not purchased.

In addition, the use of two terminals, especially at point B, results in double the amount of electrical waste and electronic equipment. If the end-user switches network operator, one provider's fully functional mandatory terminal may have to be replaced with the new provider's mandatory terminal, which would ultimately be completely unnecessary.

The amount of electrical waste could be significantly reduced by a more conscious use of electronic devices. The best solution in this respect would be to define the NTP at point A and thus the possibility of using a single, integrated terminal device.

Casalecchio di Reno, November 21st, 2019

Papadopoulos, Emiliano